



KHANYISANI



Principles for Chickens for Meat



By Dr Guy Stubbs

Narrative by Amie Harms

Artwork by Carissa Gagashi



Supplies you will need:

- Poles**
3m long - 2 poles
3.6m long - 1 pole
1.5m long - 6 poles
- Wire and wire cutters**
- Nails and hammer**
- Saw**
- Corrugated iron**
- Chicken mesh**
- Measuring tape**
- 2L plastic bottle**
- UV Mielie Bags**
- String**

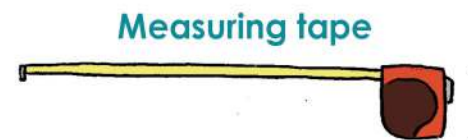

Measuring tape

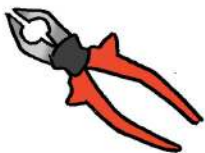

Wire and wire cutters



Nails and hammer

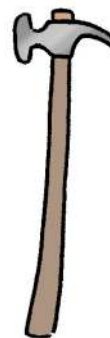

2L bottle

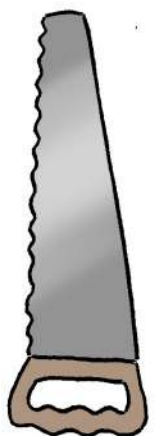

Saw



1x 3.6m

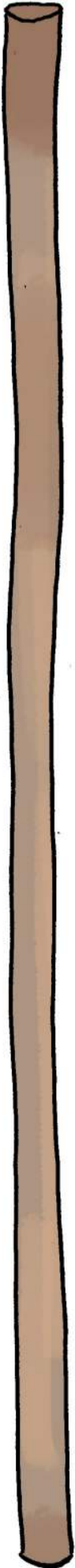

2x 3m

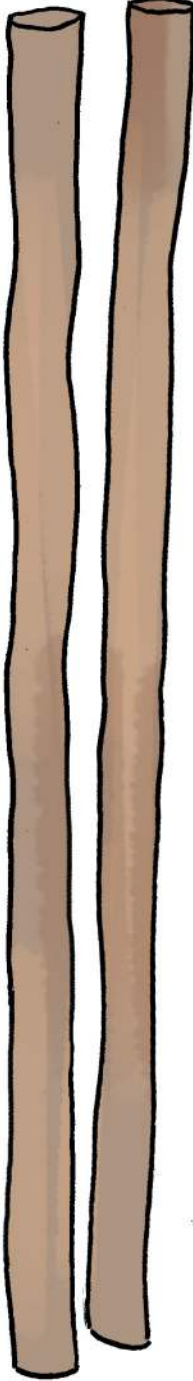

6x 1.5m

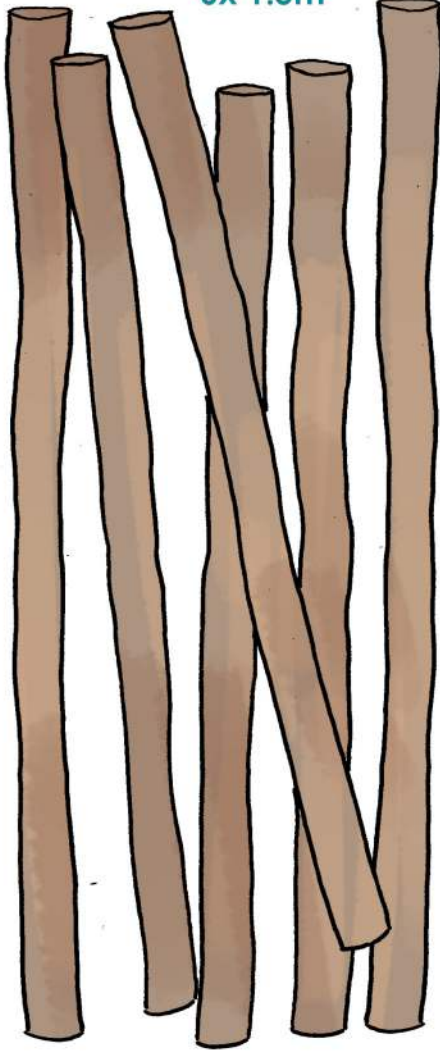

Corrugated iron

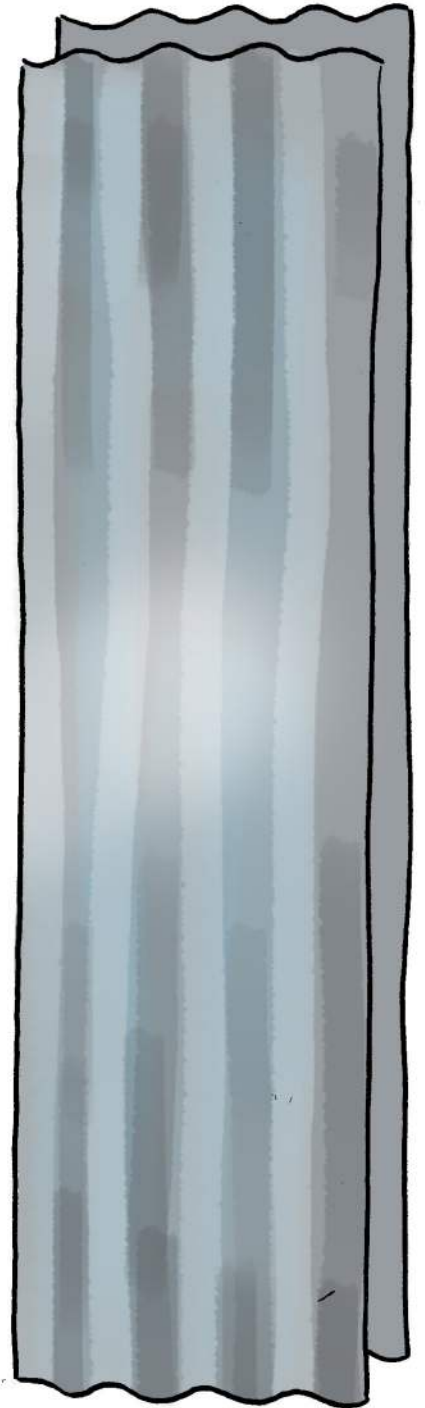

Chicken mesh

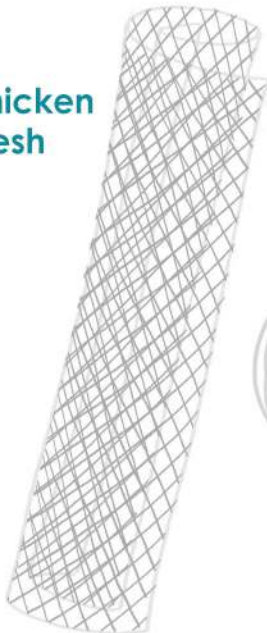

Mielie meal bags + string



Principle 1: Collect building materials from free sources, like recycling and natural materials from nature.

Using readily available local resources and recycling materials can help you make quick profits. This is because the capital costs are kept low.

For example, harvesting tree poles from a forest for building the chicken coop lowers the need for expensive materials.

Principle 2: Build a brooder.

Use bricks to make a small, enclosed area measuring 1x1m for 10-day-old chicks. Make sure the walls block wind and place sawdust on the floor for warmth.

Also, place a paraffin lamp on a brick in the middle, or use an old-fashioned light bulb to create heat that is like the warmth a mother hen would give her chicks.

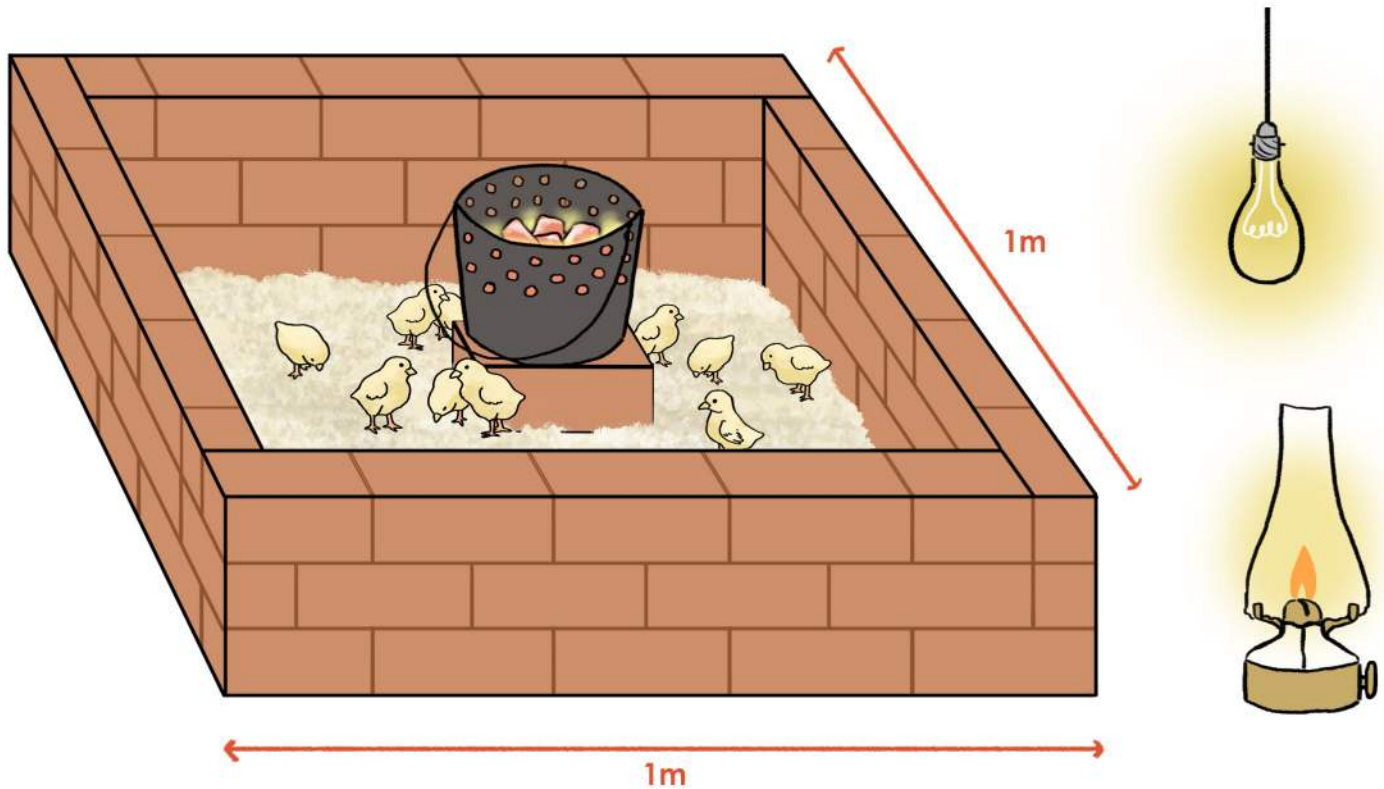

Principle 3: Make feeders and drinkers for the day-old chicks.

Put sterilized (very clean) stones or marbles in a shallow plate to prevent chicks from falling into the water.



Principle 4: Only use day-old chicks that have been bred for broiler raising.

Village chickens take 5 months to reach 1 KG, so they are not good enough for quality meat. Rather get broiler chicks that take 6 weeks to grow to 1.5 KG for the best meat production.

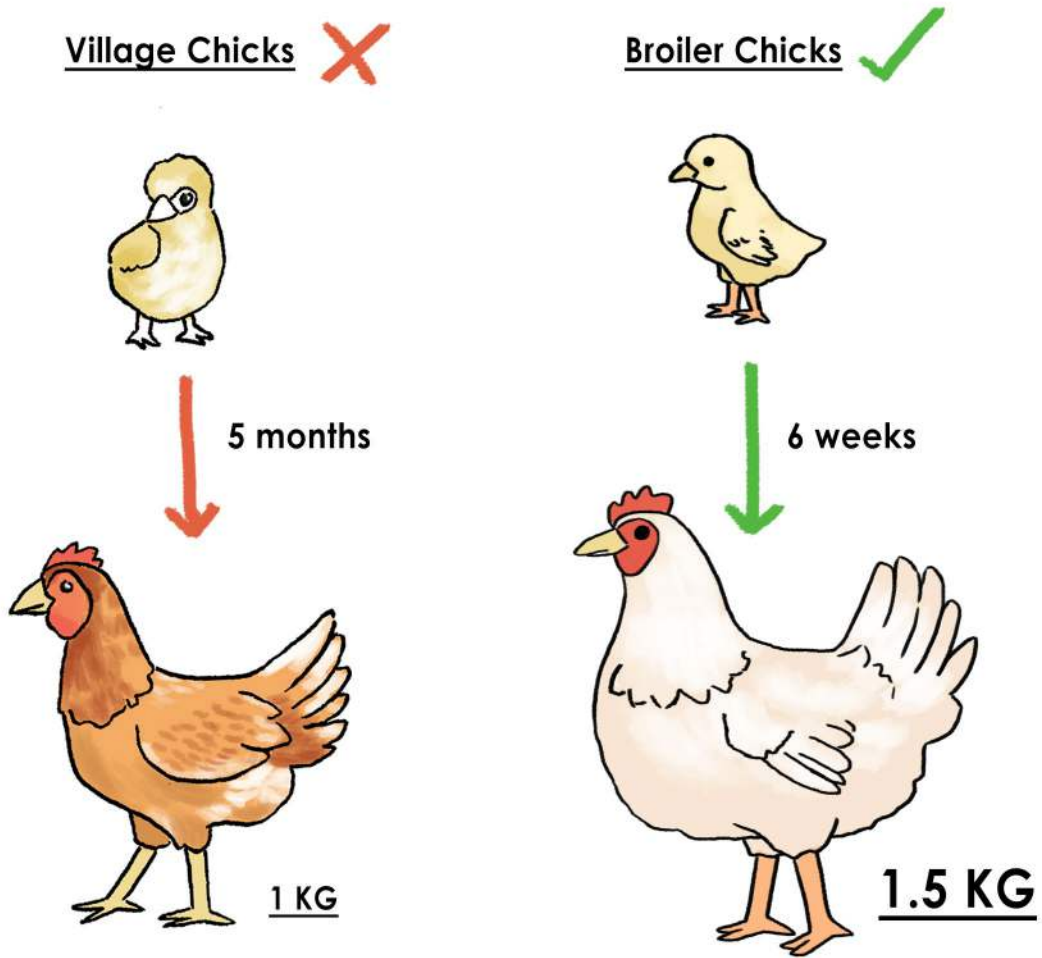

Principle 5: Make sure the day-old chicks you buy have been inoculated (immunised).

Chickens can get diseases easily. When they are inoculated or immunised, the risk of them getting diseases is lowered. Ask the seller if they can give you proof of inoculation.

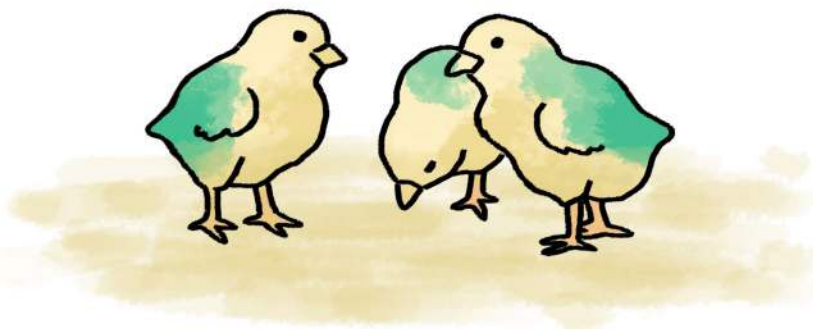

Principle 6: Feed day-old chicks a stress pack.

Add a stress pack to the day-old chicks' water. Stress packs have vitamins and supplements that help nourish chicks and relax them.

You can buy stress packs from local farming or livestock shops.

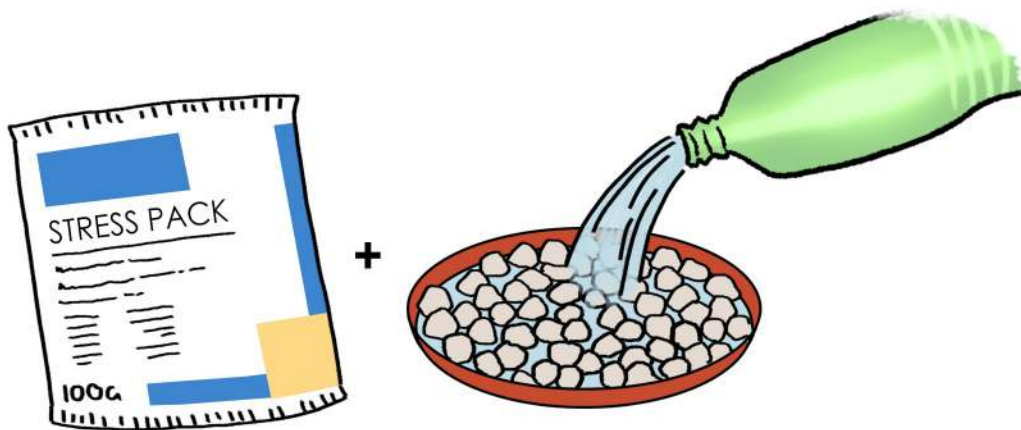

Principle 7: Feed the day-old chicks Starter Mash.

Give each chick 1 KG of Starter Mash spread over the first two weeks while they are in the brooder. Additionally, add a stress pack to the water.

Use a shallow plate for the starter mesh.

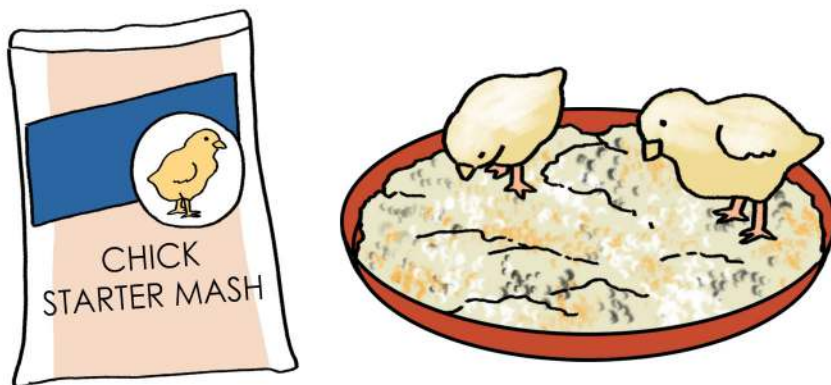

Principle 8: Build an A-frame chicken coop using natural or recycled resources.

Building a strong A-frame shelter for the chicken coop is the most cost-effective method. It can also be used as a Chicken Tractor (this is a chicken coop that can be moved around).

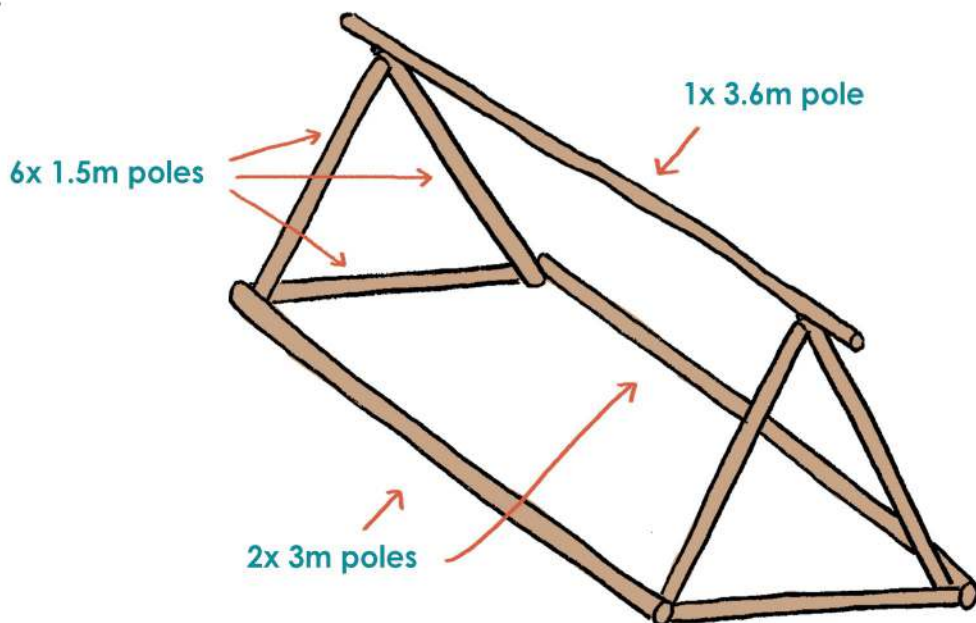

Principle 9: Attach chicken mesh and corrugated iron roofing to the A-frame chicken coop.

Attaching chicken mesh to the coop's frame is essential for creating a safe, predator-resistant shelter while making sure the chickens get enough light and air.

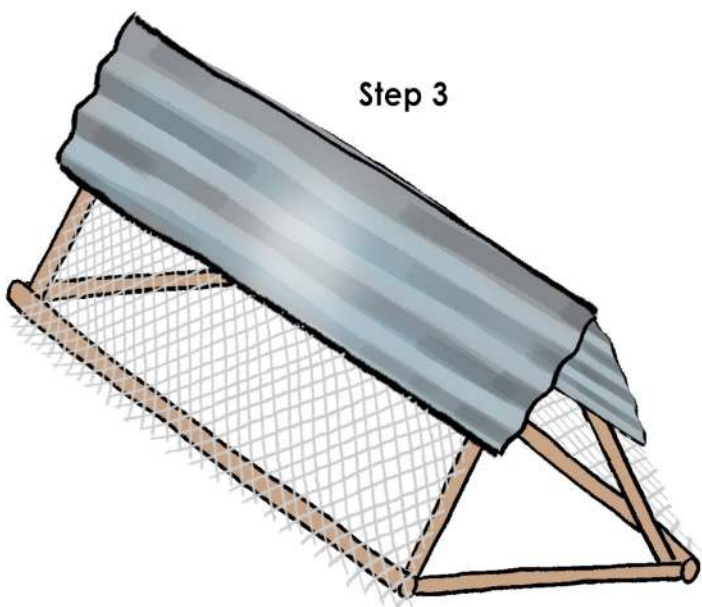
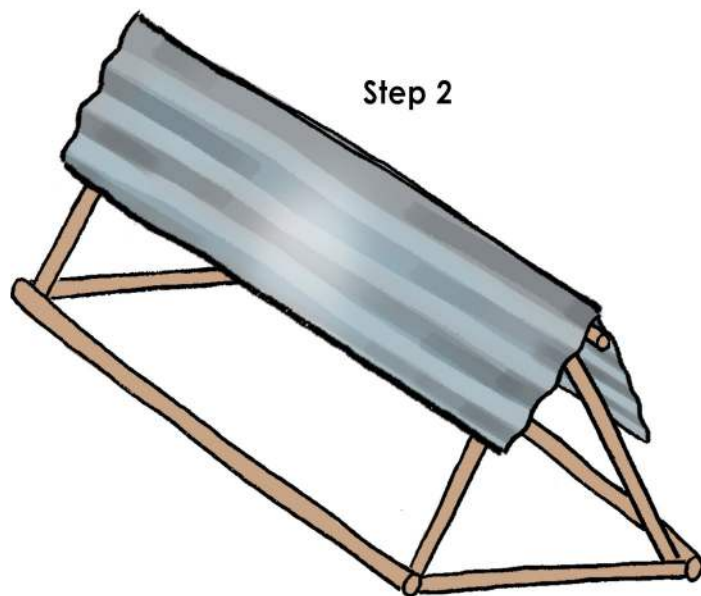
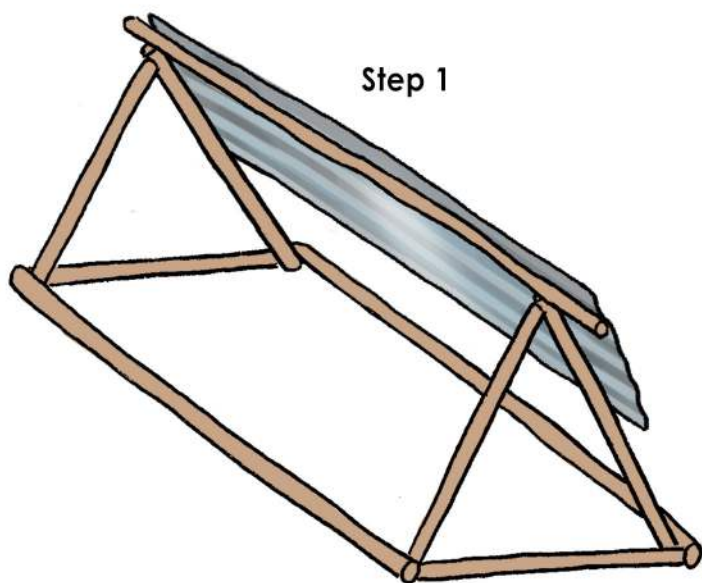

Step 4
Make doors at the bottom to access feeders.

Wire mesh on outside.

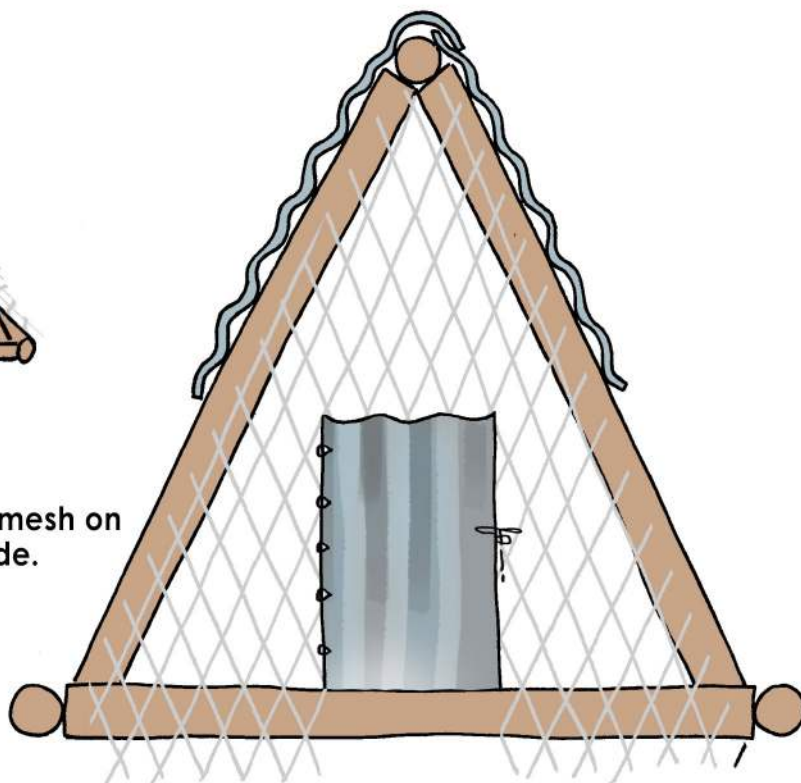

Principle 10: Use ultraviolet-protected mielie meal bags to make tent flaps.

Attach recycled ultraviolet-protected maize meal bags to the chicken coop. In rainy, windy, or cold conditions, leave them against the mesh to protect the chickens from the elements. When it's hot, lift them to let air flow and provide shade.

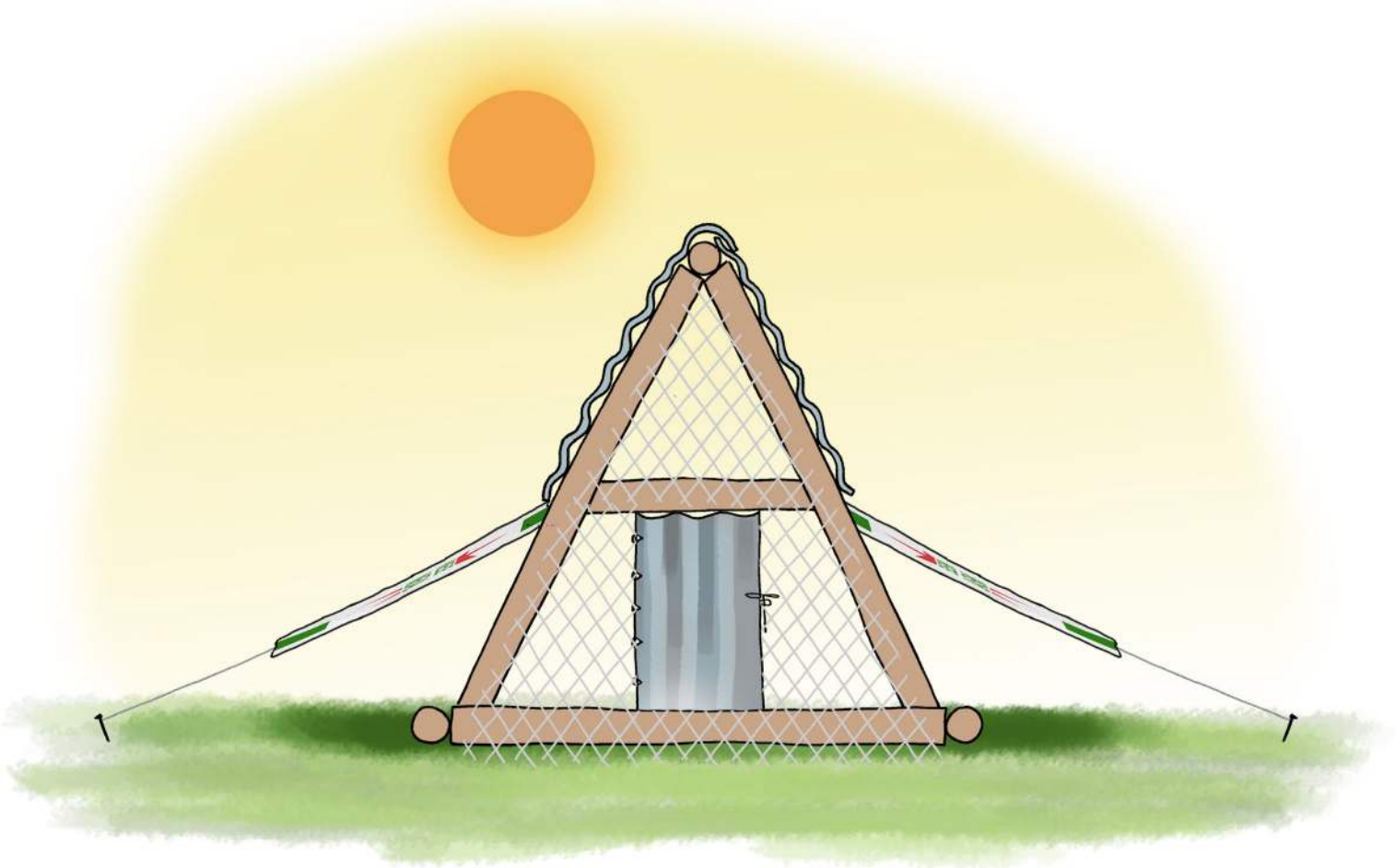

Principle 11: Make cheap feeders and drinkers using recycled 2L plastic bottles for bigger chickens.

Use recycled plastic bottles to make feeders and drinkers. This is a cheap method that is also eco-friendly, lowering waste and costs.

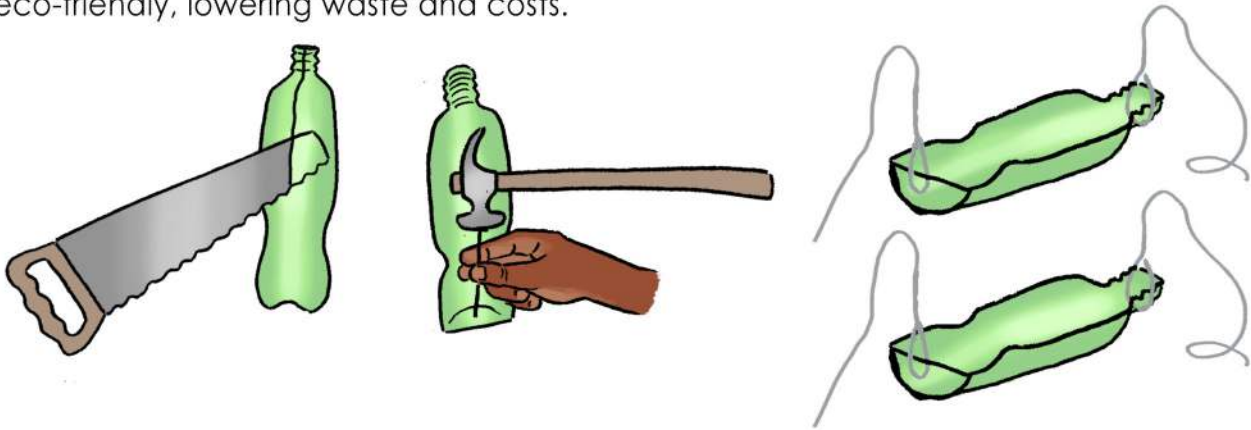

Principle 12:

Hang feeding and drinking bowls from the coop.

When you move the chicken coop, the feeders and drinkers go with it.

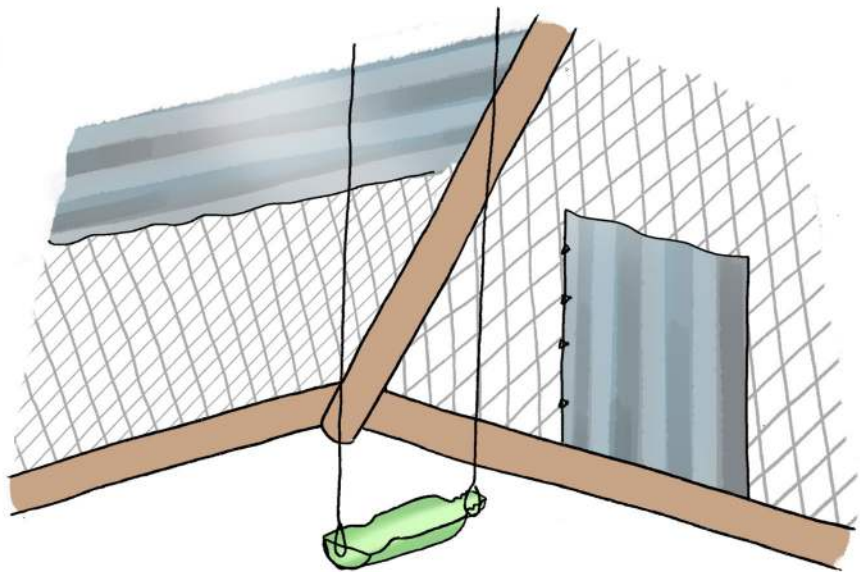

Principle 13: Move the chickens to the A-Frame coop and transition to feeding them with Grower pellets.

Feed each chicken 2 KG of Grower pellets for the following two weeks in the chicken coop.

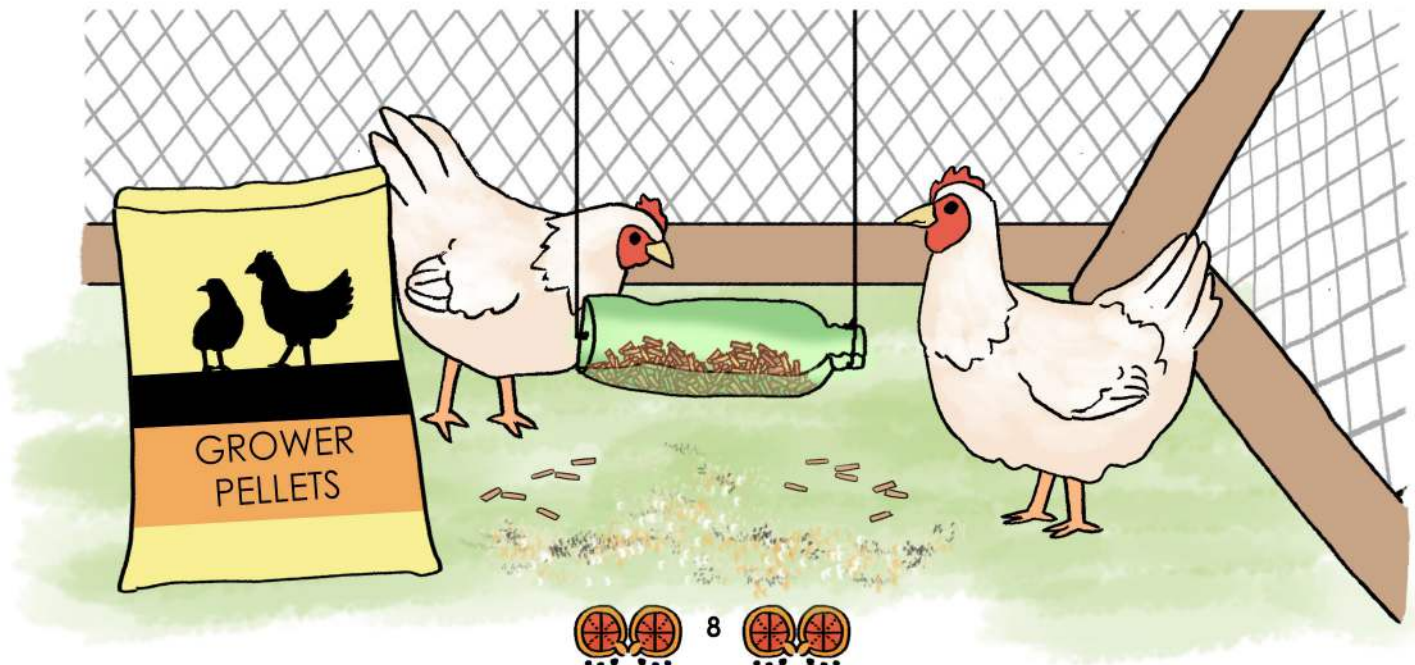

Principle 14: End by feeding the chickens Finisher pellets.

Feed each chicken 1 KG of Finisher pellets for the last two weeks in the chicken coop to remove hormones and chemicals from the meat.



Principle 15: Feed chickens a mixture of fowl feed, kitchen scraps, and greens.

A balanced diet is essential for healthy and tasty chickens. Feed the chickens a combination of mixed fowl feed, kitchen scraps, and green vegetables and grass to lower feeding costs. This feeding method also gives the chickens essential nutrients and encourages natural foraging behaviour.



Bread

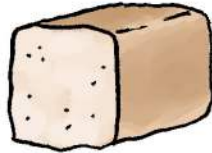

Pap or rice

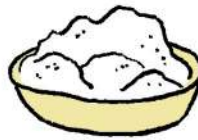

Green vegetables

Principle 16: Allow the chickens to sunbathe.

Chickens get itchy, so it is important to let them lie in the sun for skin health and comfort.

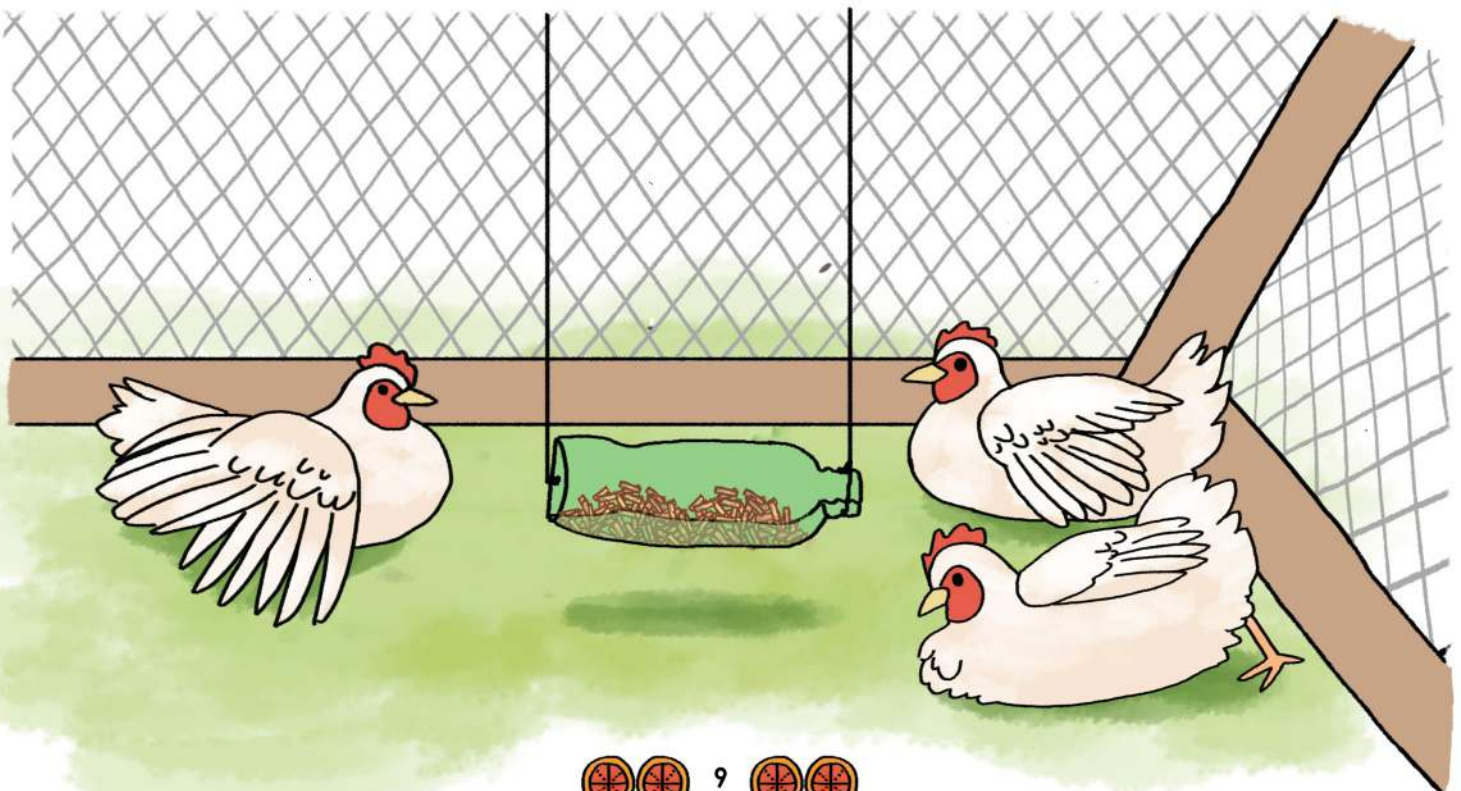

Principle 17: Make sure the chickens always have feed and water.

Never allow feed and water to run out. Meat chickens must always have access to food and water for the best weight gain.

Principle 18: Move the chicken coop around on grass or spinach for fresh grazing.

Regularly moving the chicken coop to new areas offers hens access to fresh grass and forage. Allowing hens to free-range by moving the coop over green grass or spinach encourages natural behaviour and improves the meat quality, resulting in happier, less stressed chickens with better taste.

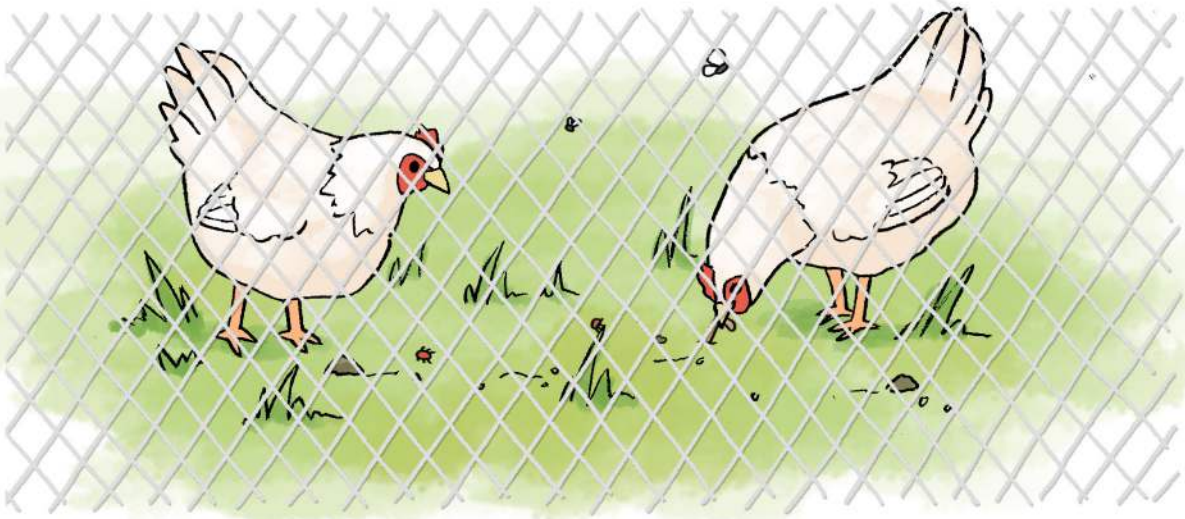

Principle 19: Plant spinach where the coop has been moved to maintain a green food source.

Planting spinach in areas where the chicken coop has been moved encourages a continuous supply of fresh greens, enriching the chickens' diet and improving the meat's nutritional content. Additionally, the chickens will provide good-quality manure for growing the spinach!

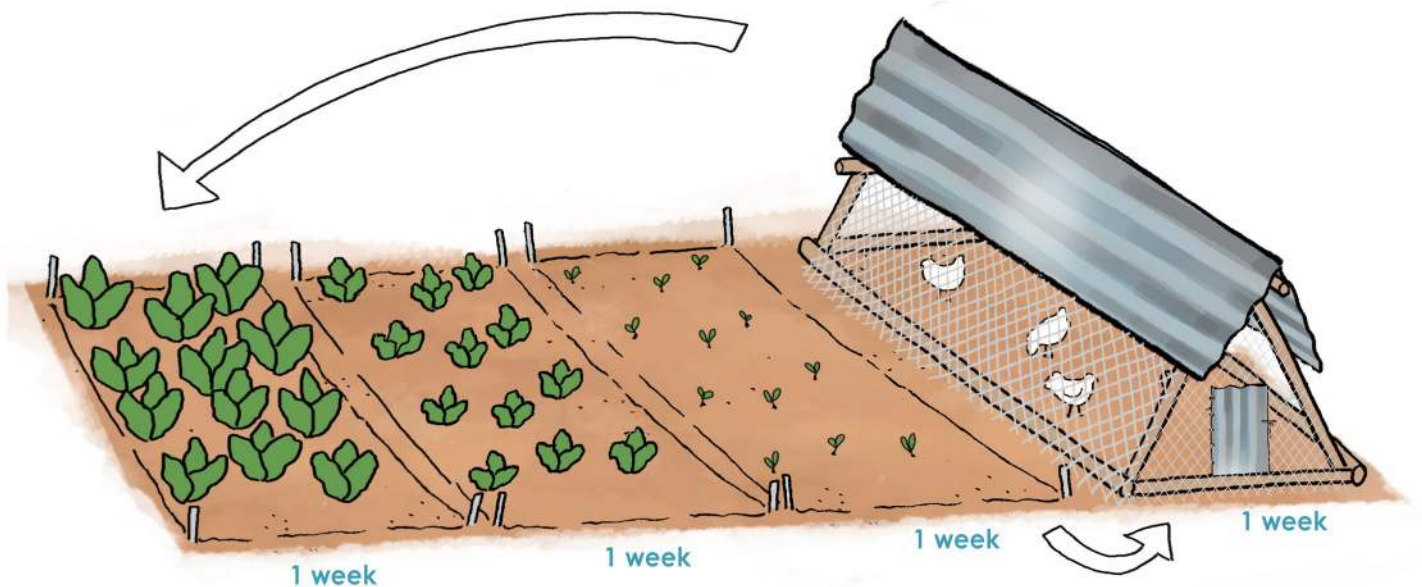



Summary of the Principles of Chickens for Meat (Checklist)

1. Collect building materials from free sources, like recycling and natural materials from nature.
2. Build a brooder.
3. Make feeders and drinkers for the day-old chicks.
4. Only use day-old chicks that have been bred for broiler raising.
5. Make sure the day-old chicks you buy have been inoculated (immunised).
6. Feed day-old chicks a stress pack.
7. Feed the day-old chicks Starter Mash.
8. Build an A-frame chicken coop using natural or recycled resources.
9. Attach chicken mesh and iron materials to the frame.
10. Use ultraviolet-protected maize meal bags to make tent flaps.
11. Make cheap feeders and drinkers using recycled 2L plastic bottles for bigger chickens.
12. Hang feeding and drinking bottles from the coop.
13. Move the chickens to the A-Frame coop and transition to feeding them with Grower pellets.
14. End by feeding the chickens Finisher pellets.
15. Feed chickens a mixture of fowl feed, kitchen scraps, and greens.
16. Allow the chickens to sunbathe.
17. Make sure the chickens always have feed and water.
18. Move the chicken coop around on grass or spinach for fresh grazing.
19. Plant spinach where the coop has been moved to maintain a green food source.



Business Plan for Selling Chickens

Buy 10-day old chicks for R10 each	R100.00
------------------------------------	---------

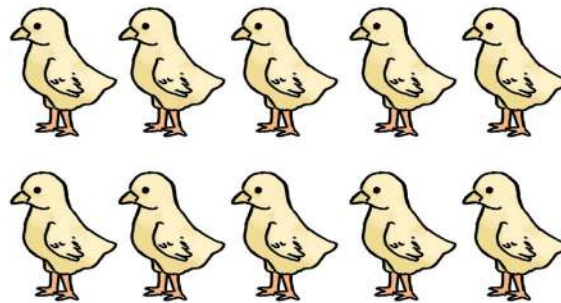

10KG Starter Mash	R100.00
20KG Grower Mash	R200.00
10KG Finisher Pellets	R100.00
Stresspack	R10.00
Total	R510.00

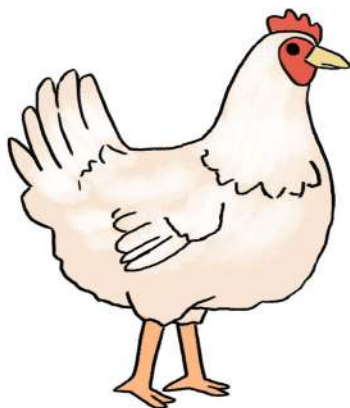

Sell chickens when they are 1.5GK for R100 each

10 chickens at R100 each	R1000.00
Expenses	-R510.00

Profit for 10 chickens = R490



Chesanyama Business Plan



Adding value

Cost per chicken is R510 expenses ÷ 10 = R51

You can divide a chicken into 8 pieces to sell on a plate

1 chicken ÷ 8 pieces =
R6.40 per piece



Cost for chicken piece =	R6.40
Cost for some pap =	R7.50
Cost for some spinach =	R7.50
Total	R21.40

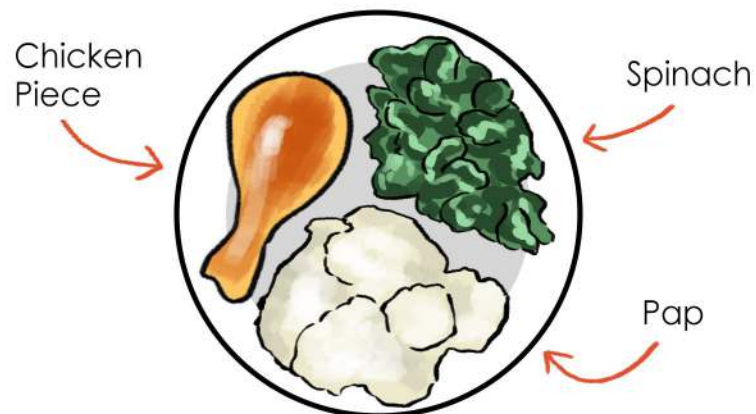

Sell plates of cooked food for R50 each

8 X plates of food cost	-R171.20
SELL 8 X plates of food for R50	R400.00

Profit for 8 plates of food (1 chicken) = R228.80

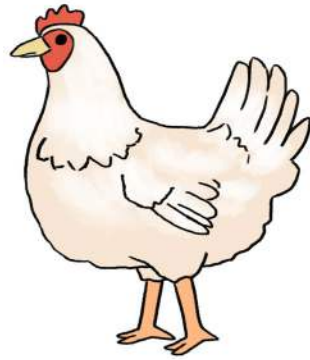

Proverbs 16:3

Commit your work to the Lord,
and your plans will be established.



www.childvision.co.za
www.africanhoneybee.co.za